

Connection and Operation

Names and Functions of Driver Parts

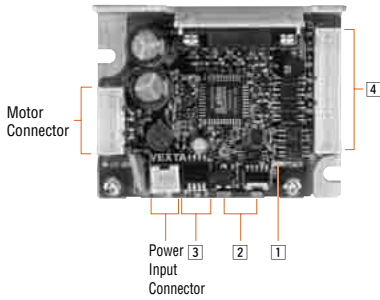

1 Power Input Display

Color	Function	When Activated
Green	Power supply indication	Lights when power is on.

2 Current Adjustment Switch

Indication	Switch Name	Function
RUN	Motor run current switch	For adjusting the motor running current
STOP	Motor stop current potentiometer	For adjusting the current at motor standstill

3 Function Select Switch

Indication	Switch Name	Function
1	Pulse input mode switch	Switches between 1-pulse input and 2-pulse input.
2, 3, 4	Step angle setting switch	These switches can be set to the desired resolution from the five resolution levels.

Step Angle Setting Switch

SW-2	SW-3	SW-4	Microstep/Step	Resolution	Step Angle
OFF	OFF	OFF	1	200	1.8°
OFF	OFF	ON	2	400	0.9°
OFF	ON	OFF	4	800	0.45°
OFF	ON	ON	8	1600	0.225°
ON	OFF	OFF	16	3200	0.1125°

Notes:

- Use of any setting other than the combinations listed in the table will automatically set the microstep to "1" and the motor will operate at the basic step angle.
- The step angle is calculated by dividing the basic step angle by the number of microsteps. The above figures are based on a basic step angle of 1.8°.
- With the high-resolution type, the basic step angle and resolution are 0.9° and 400 respectively.
- The step angle set with the step angle setting switches will become effective when the "Step Angle Select" (CS) signal input is OFF.
- Do not change the CS (step angle select) signal input or step angle setting switches while the motor is operating. It may cause the motor to misstep and stop. Change the step angle setting switches, when the "Step Angle Select" signal input is OFF and the "Excitation Timing" signal output is ON.

4 Input/Output Signal

Indication	Input/Output	Pin No.	Signal Name	Function
CN2	Input signal	1	Pulse signal (CW pulse signal)	Operation command pulse signal (The motor will rotate in the CW direction when in 2-pulse input mode.)
		2		
		3	Rotation direction signal (CCW pulse signal)	Rotation direction signal Photocoupler OFF: CCW, Photocoupler ON: CW (The motor will rotate in the CCW direction when in 2-pulse input mode.)
		4		
		5	All windings off signal	Cuts the output current to the motor and allows the motor shafts to be rotated by external force.
		6		
		7	Step angle select signal	The motor will operate at the basic step angle regardless of the settings of the step angle setting switches.
		8		
		9	Automatic current cutback release signal	This signal is used to disable the automatic current cutback function.
		10		
Output signal		11	Excitation timing signal	Outputs signals when the excitation sequence is at STEP "0."
		12		

● Connection Diagrams

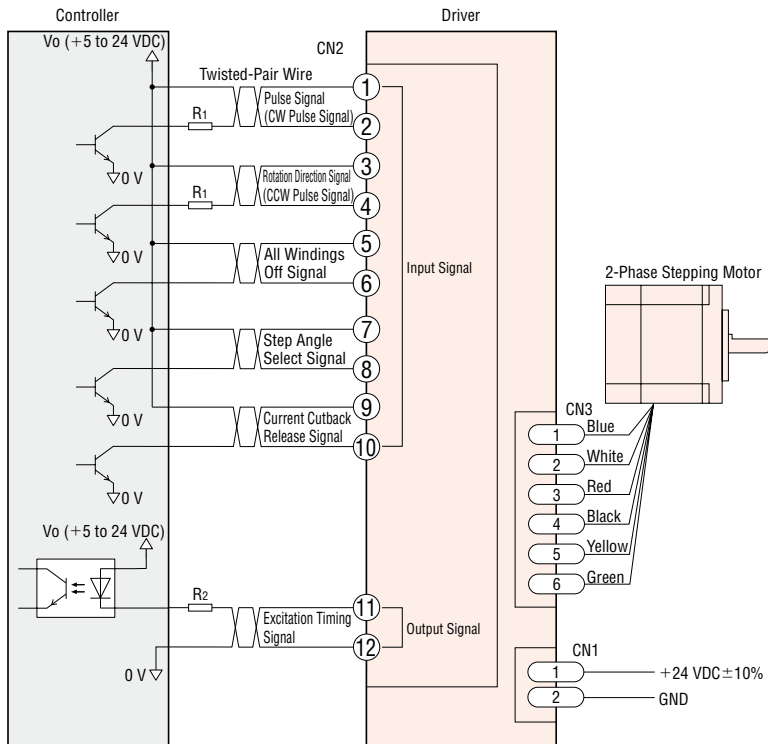

◇ Input Signal Connection

● Pulse (CW) Signal/Rotation Direction (CCW) Signal
Signals can be connected directly when 5 VDC is supplied. When the voltage exceeds 5 VDC, connect an external resistor (R_1) to keep input current at 20 mA or less. When 5 VDC or more is supplied without the external resistor, the internal components get damaged.

Example: If the voltage is 24 VDC, connect a resistor (R_1) of 1.5 to 2.2 k Ω and 0.5 W or more.

● All Windings Off Signal/Step Angle Select Signal/Automatic Current Cutback Release Signal
Signals can be connected directly when 5 to 24 VDC is supplied.

◇ Output Signal Connection

Use the output signal at 24 VDC or less and 10 mA or less. If these specifications are exceeded, the internal components may get damaged. Check the specification of the connected equipment. If the current exceeds 10 mA, connect an external resistor R_2 .

◇ Power Supply

Use a power supply that can supply sufficient input current. When power supply capacity is insufficient, a decrease in motor output can cause the following malfunctions:

- Motor does not rotate properly at high-speed.
- Slow motor startup and stopping

◇ Notes on Wiring

- Use twisted-pair wires of AWG24 to 22 (0.2 to 0.3 mm²) and 2 m (6.6 ft.) or less in length for the signal lines.
- Note that as the length of the pulse signal line increases, the maximum transmission frequency decreases.
- Use wires of AWG22 (0.3 mm²) for power supply lines. When assembling the connectors, use the hand-operated crimp tool or driver lead wire set crimped with connector (sold separately). The crimp tool is not included with the package. It must be purchased separately.
- Signal lines should be kept at least 2 cm (0.79 in.) away from power lines (power supply lines and motor lines). Do not run the signal lines in the same duct as power lines or bundle them together.
- If noise generated by the motor cable or power supply cable causes a problem, try shielding the cables or insert ferrite cores.
- Incorrect connection of DC power input will lead to driver (circuit) damage. Make sure that the polarity is correct before turning power on.

● Description of Input/Output Signals

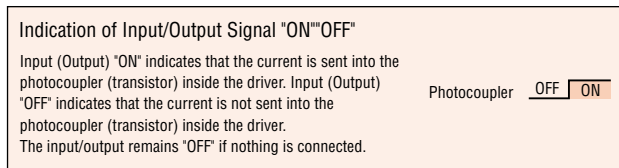

Pulse (CW) and Rotation Direction (CCW) Input Signal

◇ Input Circuit and Sample Connection

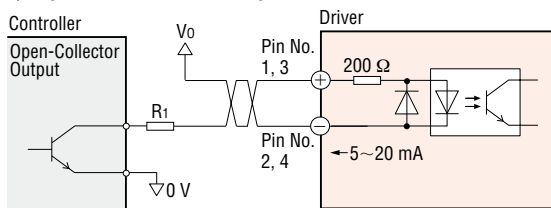

◇ Pulse Waveform Characteristics

● 1-Pulse Input Mode

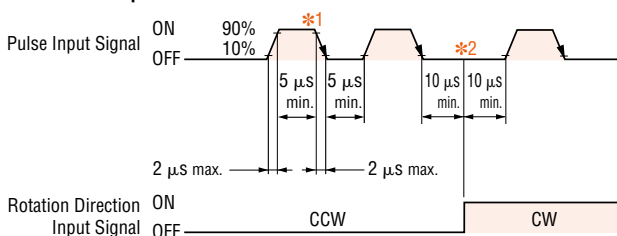

● 2-Pulse Input Mode

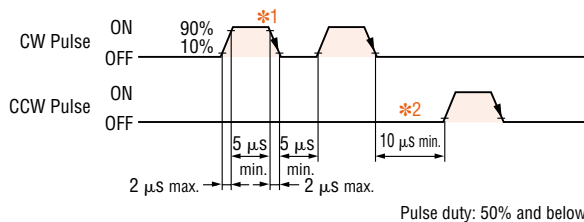

- *1 The shaded area indicates when the photocoupler diode is ON. The motor moves when the photocoupler state changes from ON to OFF.
- *2 The minimum interval time when changing rotation direction 10 μ s is shown as a response time of circuit. This value varies greatly depending on the motor type and load inertia.

◇ Pulse Signal Characteristics

- Keep the "Pulse" signal at the "photocoupler OFF" state when no pulses are being input.
- In 1-pulse input mode, leave the "Pulse" signal at rest ("OFF") when changing rotation directions.
- In 2-pulse input mode, do not input a CW pulse and CCW pulse simultaneously.

All Windings Off (AWO)/Step Angle Select (CS)/Automatic Current Cutback Release (ACDOFF) Input Signal

◇ Input Circuit and Sample Connection

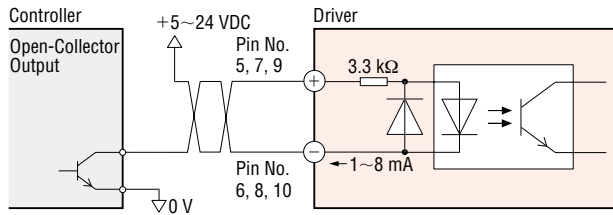

◇ All Windings Off (AWO) Input Signal

- Inputting this signal puts the motor in a non-excitation (free) state.
- This signal is used when moving the motor by external force or perform positioning manually. The photocoupler must be "OFF" when operating the motor.

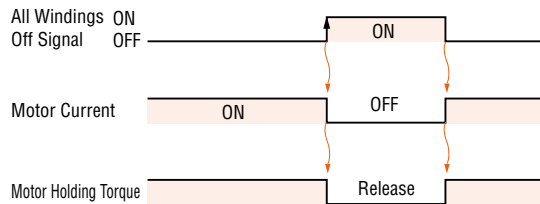

The shaded area indicates that the motor provides holding torque in proportion to standstill current set by STOP potentiometer.

- Switching the "All Windings Off" signal from "photocoupler ON" to "photocoupler OFF" does not alter the excitation sequence. When the motor shaft is manually adjusted with the "All Windings Off" signal input, the shaft will shift up to $\pm 3.6^\circ$ (geared type: $\pm 3.6^\circ$ /gear ratio) from the position set after the "All Windings Off" signal is released.

◇ Step Angle Select (CS) Input Signal

- When this signal input is "ON," the motor will operate at the basic step angle regardless of the settings of the step angle setting switches. When the signal input is "OFF," the motor will operate at the step angle set with the step angle setting switches.
- To change the step angle, do so when the "Excitation Timing" signal output is "ON" and the motor is at standstill.

◇ Automatic Current Cutback Release (ACDOFF) Input Signal

- When this signal is in the "photocoupler ON" state, the automatic current cutback function is disabled. When this signal is in the "photocoupler OFF" state, the automatic current cutback function will be activated after the motor stops (after approx. 100 ms).
- The photocoupler must be "OFF" when the motor is operating.

Excitation Timing (TIM) Output Signal

◇ Output Circuit and Sample Connection

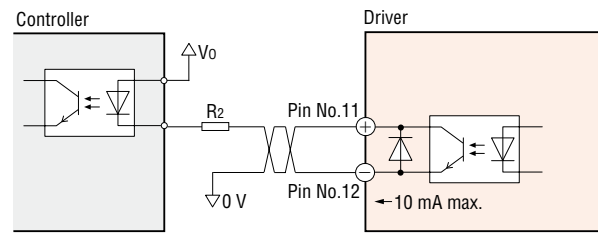

- The "Excitation Timing" signal is output when the motor excitation is in the initial stage (step "0").
- The "Excitation Timing" signal is output simultaneously with a pulse input each time the excitation sequence returns to step "0." The excitation sequence will complete one cycle for every 7.2° (3.6° for high-resolution type) rotation of the motor output shaft. Microstep/step 1: Signal is output once every 4 pulses. Microstep/step 4: Signal is output once every 16 pulses.

Timing chart at 1.8° /step (microstep/step 1)

* When connected as shown in the sample connection, the signal will be "photocoupler ON" at step "0."

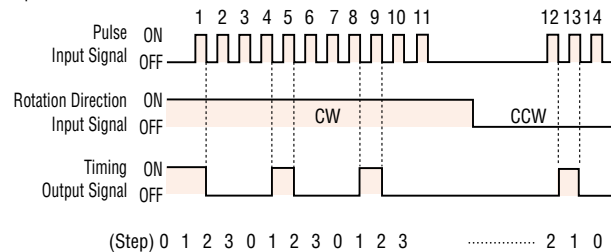

Notes:

- When power is turned on, the excitation sequence is reset to step "0" and the "Excitation Timing" signal will be output.
- When operating the motor using the "Excitation Timing" signal output, make sure the motor output shaft stops at an integral multiple of 7.2° (3.6° for high-resolution type).

● Timing Chart

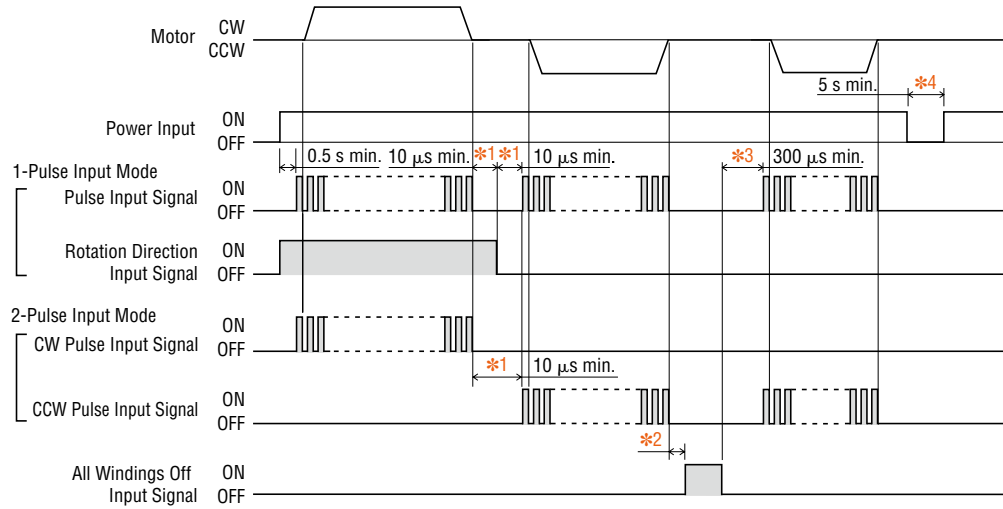

The section indicates that the photocoupler diode is emitting light.

- *1 The minimum switching time to change rotation direction signal (1-pulse input mode), and switching time to change CW, CCW pulse (2-pulse input mode) 10 μs is shown as a response time of circuit. The motor may need more time.
- *2 Depends on load inertia, load torque and starting frequency.
- *3 Never input a pulse signal immediately after switching the "All Windings Off" signal to "photocoupler OFF." The motor may not start.
- *4 Wait at least five seconds before turning on the power again.

■ List of Motor and Driver Combinations

Model names for motor and driver combinations are shown below.

Type	Model	Motor Model	Driver Model	
High-Torque Type	CMK223PAP	PK223PA*	CMD2109P	
	CMK223PBP	PK223PB*		
	CMK224PAP	PK224PA*		
	CMK224PBP	PK224PB*		
	CMK225PAP	PK225PA*		
	CMK225PBP	PK225PB*		
	High-Torque Type	CMK233PAP	PK233PA*	CMD2112P
		CMK233PBP	PK233PB*	
		CMK235PAP	PK235PA*	
		CMK235PBP	PK235PB*	
		CMK244PAP	PK244PA*	
		CMK244PBP	PK244PB*	
		CMK246PAP	PK246PA*	
		CMK246PBP	PK246PB*	
High-Resolution Type	CMK243MAPA	PK243MAA	CMD2109P	
	CMK243MBPA	PK243MBA		
	CMK244MAPA	PK244MAA	CMD2112P	
	CMK244MBPA	PK244MBA		
	CMK245MAPA	PK245MAA		
	CMK245MBPA	PK245MBA		
	High-Resolution Type	CMK264MAP	PK264MA	CMD2120P
		CMK264MBP	PK264MB	
		CMK266MAP	PK266MA	
		CMK266MBP	PK266MB	
CMK268MAP		PK268MA		
CMK268MBP		PK268MB		
Standard Type	CMK243APA	PK243-01AA	CMD2109P	
	CMK243BPA	PK243-01BA		
	CMK244APA	PK244-01AA	CMD2112P	
	CMK244BPA	PK244-01BA		
	CMK245APA	PK245-01AA		
	CMK245BPA	PK245-01BA		
	Standard Type	CMK256AP	PK256-02A	CMD2120P
		CMK256BP	PK256-02B	
		CMK258AP	PK258-02A	
		CMK258BP	PK258-02B	
		CMK264AP	PK264-02A	
		CMK264BP	PK264-02B	
		CMK266AP	PK266-02A	
		CMK266BP	PK266-02B	
CMK268AP		PK268-02A		
CMK268BP		PK268-02B		

Type	Model	Motor Model	Driver Model	
SH Geared Type	CMK223AP-SG7.2	PK223PA-SG7.2*	CMD2109P	
	CMK223BP-SG7.2	PK223PB-SG7.2*		
	CMK223AP-SG9	PK223PA-SG9*		
	CMK223BP-SG9	PK223PB-SG9*		
	CMK223AP-SG10	PK223PA-SG10*		
	CMK223BP-SG10	PK223PB-SG10*		
	CMK223AP-SG18	PK223PA-SG18*		
	CMK223BP-SG18	PK223PB-SG18*		
	CMK223AP-SG36	PK223PA-SG36*		
	CMK223BP-SG36	PK223PB-SG36*		
	CMK243APA-SG3.6	PK243A1A-SG3.6		CMD2109P
	CMK243BPA-SG3.6	PK243B1A-SG3.6		
	CMK243APA-SG7.2	PK243A1A-SG7.2		
	CMK243BPA-SG7.2	PK243B1A-SG7.2		
	CMK243APA-SG9	PK243A1A-SG9		
	CMK243BPA-SG9	PK243B1A-SG9		
	CMK243APA-SG10	PK243A1A-SG10	CMD2109P	
	CMK243BPA-SG10	PK243B1A-SG10		
	CMK243APA-SG18	PK243A1A-SG18		
	CMK243BPA-SG18	PK243B1A-SG18		
CMK243APA-SG36	PK243A1A-SG36			
CMK243BPA-SG36	PK243B1A-SG36			
SH Geared Type	CMK264APA-SG3.6	PK264A2A-SG3.6	CMD2120P	
	CMK264BPA-SG3.6	PK264B2A-SG3.6		
	CMK264APA-SG7.2	PK264A2A-SG7.2		
	CMK264BPA-SG7.2	PK264B2A-SG7.2		
	CMK264APA-SG9	PK264A2A-SG9		
	CMK264BPA-SG9	PK264B2A-SG9		
	CMK264APA-SG10	PK264A2A-SG10		
	CMK264BPA-SG10	PK264B2A-SG10		
	CMK264APA-SG18	PK264A2A-SG18		
	CMK264BPA-SG18	PK264B2A-SG18		
CMK264APA-SG36	PK264A2A-SG36			
CMK264BPA-SG36	PK264B2A-SG36			

- * If you are purchasing only a motor for maintenance purpose, etc., motor lead wire/connector assembly and connector will not be supplied. They must be purchased separately. An accessory motor lead wire/connector assembly is available.

→ Page 30