

Orientalmotor

ORIENTAL MOTOR U.S.A. Corp.
570 Alaska Avenue
Torrance, CA 90503
1-800-GO-VEXTA (468-3982)

Item # AZM46AK-HS50, 1.65 in. (42 mm) AZ Series Harmonic Gear Stepper Motor with Mechanical Absolute Encoder (Gear Ratio: 50:1) (DC Input)



α STEP Hybrid Step-Servo

The α STEP AZ Series stepper motor offers closed loop control, substantially reduces heat generation from the motor and by incorporating the newly developed Mechanical Absolute Encoder, absolute-type positioning is available, without battery back up or external sensors to buy.

- Requires α STEP AZ Series Driver

*Connection Cables required (sold separately)



Web Price

\$1,089.00

[Specifications](#) | [Dimensions](#) | [Speed-Torque](#) | [Rotation](#) | [System](#) | [Product Number](#)

Specifications

Lead Time¹ Please contact Sales for Lead-time.

Return Policy This product cannot be cancelled or returned once the order has been processed.

Frame Size 1.65 in

Motor Length 4.02 in.

Driver Voltage Input Power DC

Speed-Torque Characteristics

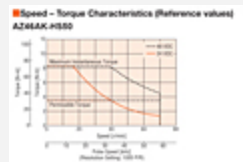

Speed - Torque Characteristics

Holding Torque 1175 oz-in



Holding Torque at Motor Standstill	1062 oz-in
Type	Mechanical Absolute Encoder
Shaft/Gear Type	Harmonic Gear
Gear Ratio (X:1)	50 :1
Lost Motion	1.55 arc min or less
Shaft	Single
Electromagnetic Brake	Not Equipped
Connection Type	Cable
Resolution (Resolution Setting: 1000 P/R)	0.0072 °/Pulse
Permissible Speed Range (r/min)	0 ~ 70
Rotor Inertia	0.39 oz-in ²
Stop Position Accuracy	±4 arc minutes (±0.067°)
Shaft Runout	0.05 mm (0.002 in.) T.I.R.
Concentricity	0.075 mm (0.003 in.) T.I.R.
Permissible Overhung Load	0 in. from Shaft End = 40 lb 0.2 in. from Shaft End = 49 lb 0.39 in. from Shaft End = 60 lb 0.59 in. from Shaft End = 81 lb 0.79 in. from Shaft End = 114 lb
Perpendicularity	0.075 mm (0.003 in.) T.I.R.
Permissible Thrust Load	49 lb
RoHS Compliant	These products do not contain substances that exceed the regulation values in the RoHS Directive.
Safety Standards	CE
California Proposition 65	<p>⚠ CA WARNING Cancer risk from exposure to Nickel. See www.P65Warnings.ca.gov Risk of reproductive harm from exposure to Di-n-hexyl phthalate (DnHP). See www.P65Warnings.ca.gov Risk of cancer and reproductive harm from exposure to Di(2-ethylhexyl phthalate (DEHP). See www.P65Warnings.ca.gov See "?" or copy/paste www.P65Warnings.ca.gov in your browser.</p>

CE Marking	EMC Directives
Insulation Class	Class B [130°C (266°F)]
Insulation Resistance	100 MΩ or more when 500 VDC megger is applied between the following places: Case - Motor and sensor windings
Dielectric Strength	Sufficient to withstand the following for 1 minute: Case - Motor and sensor windings 1.5 kVAC 50 Hz or 60 Hz
Ambient Temperature	0 ~ 40°C (32 ~ 104°F) (non-freezing)
Ambient Humidity	85% or less (Non-condensing)
Operating Atmosphere	Use in an area without corrosive gases and dust. The product should not be exposed to water, oil or other liquids.
Degree of Protection	IP66 (excluding the mounting surface and connector)



Dimensions

Dimensions Unit = mm (in.)

Motors

Harmonic Geared Type

Frame Size 42 mm (1.65 in.)

Product Name		Motor Product Name	Gear Ratio	Mass kg (lb.)
Built-In Controller	Pulse Input			
AZ46AKD-HS  -◇	AZ46AK-HS  -◇	AZM46AK-HS 	50, 100	0.65 (1.43)

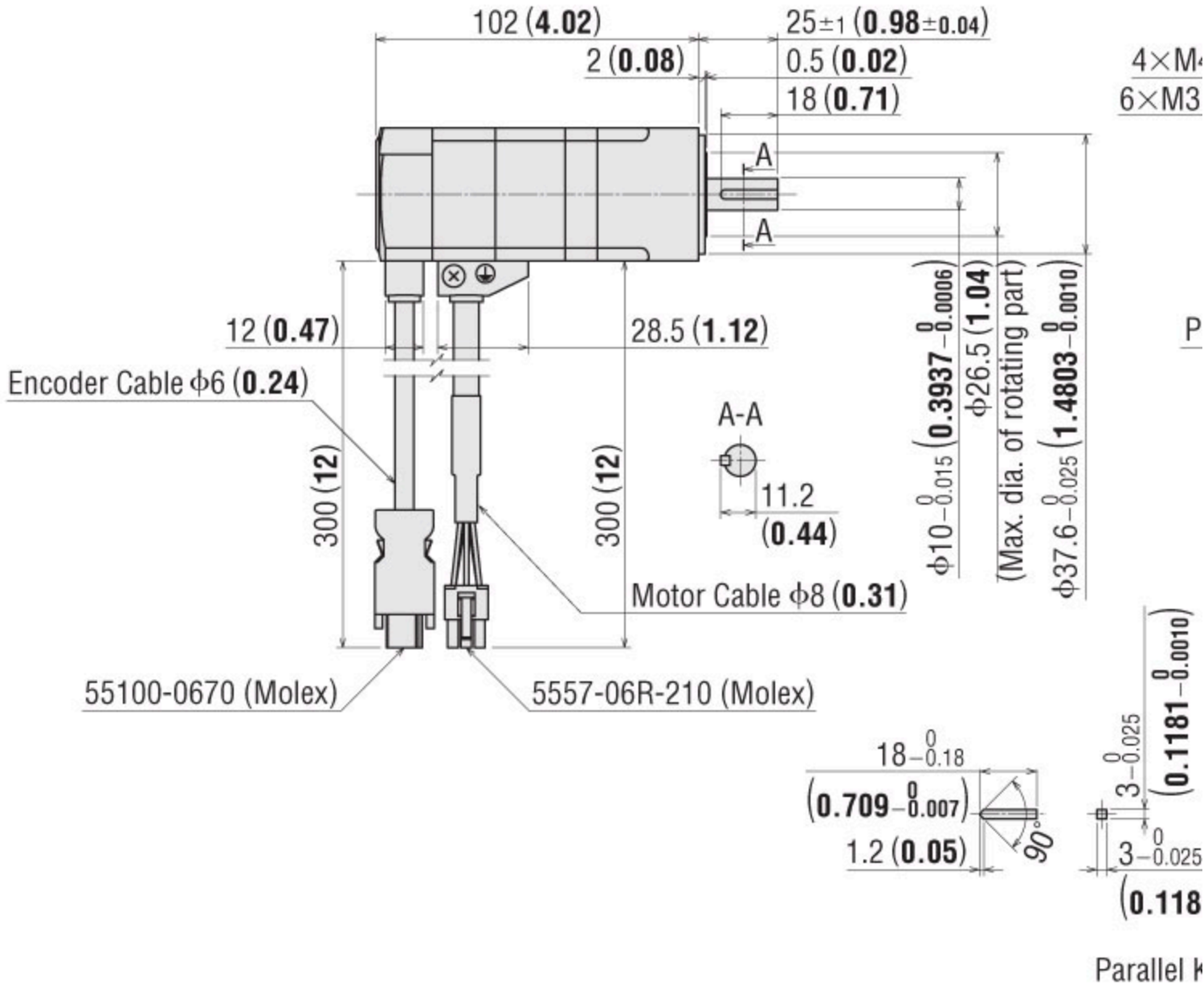

Speed-Torque

-

Load Torque - Driver Input Current Characteristic

This is the relationship between the load torque and driver input current at each speed when the motor is actually operated. From these characteristics, the power supply capacity required for use in multi-operation can be estimated. For the geared type, convert to torque and speed by the motor shaft.

Motor Shaft Speed = Gear Output Shaft Speed x Gear Ratio [r/min]

Motor Shaft Torque = Gear Output Shaft Torque / Gear Ratio [N·m (oz-in)]

AZ46□K

24 VDC

4

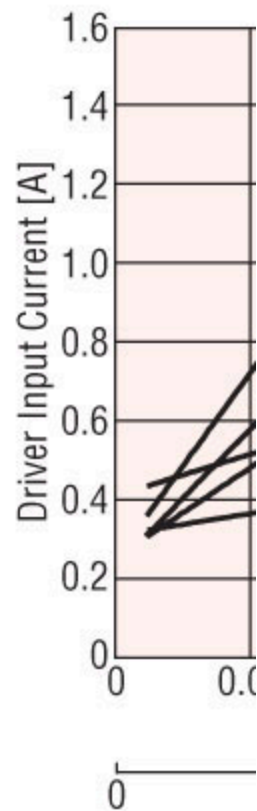
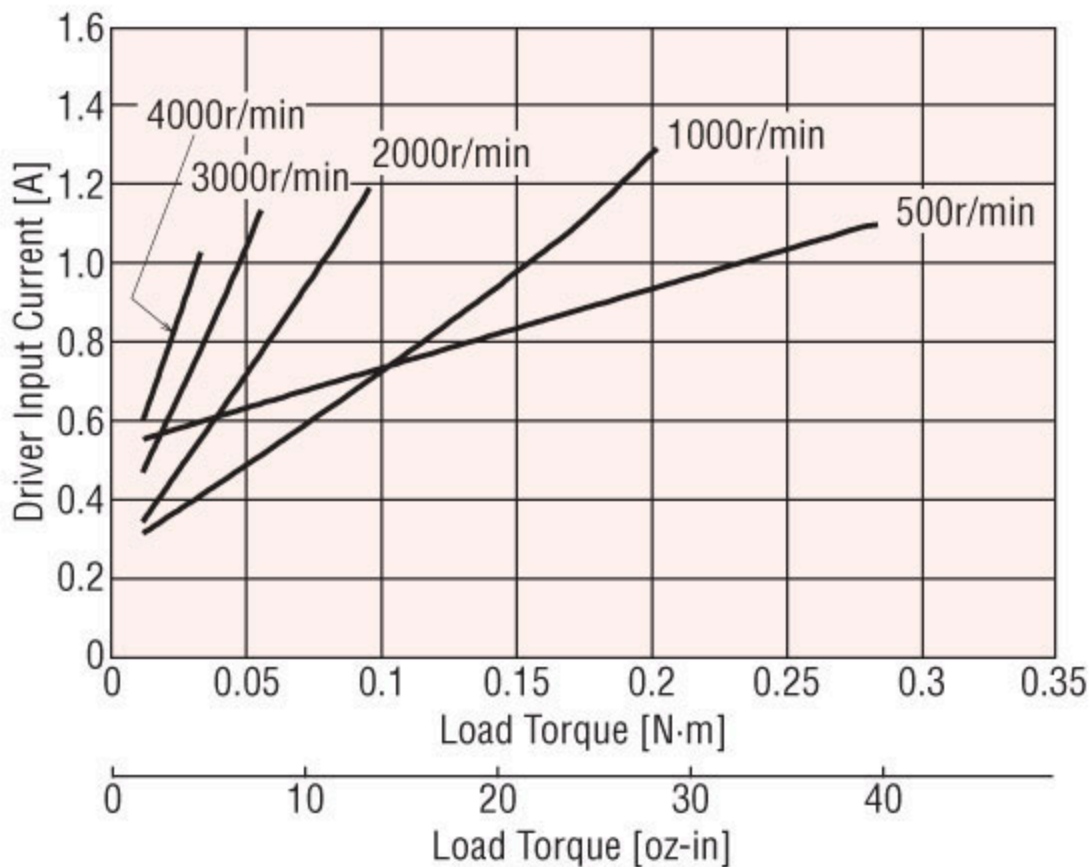

Speed – Torque Characteristics (Ref AZ46AK-HS50)

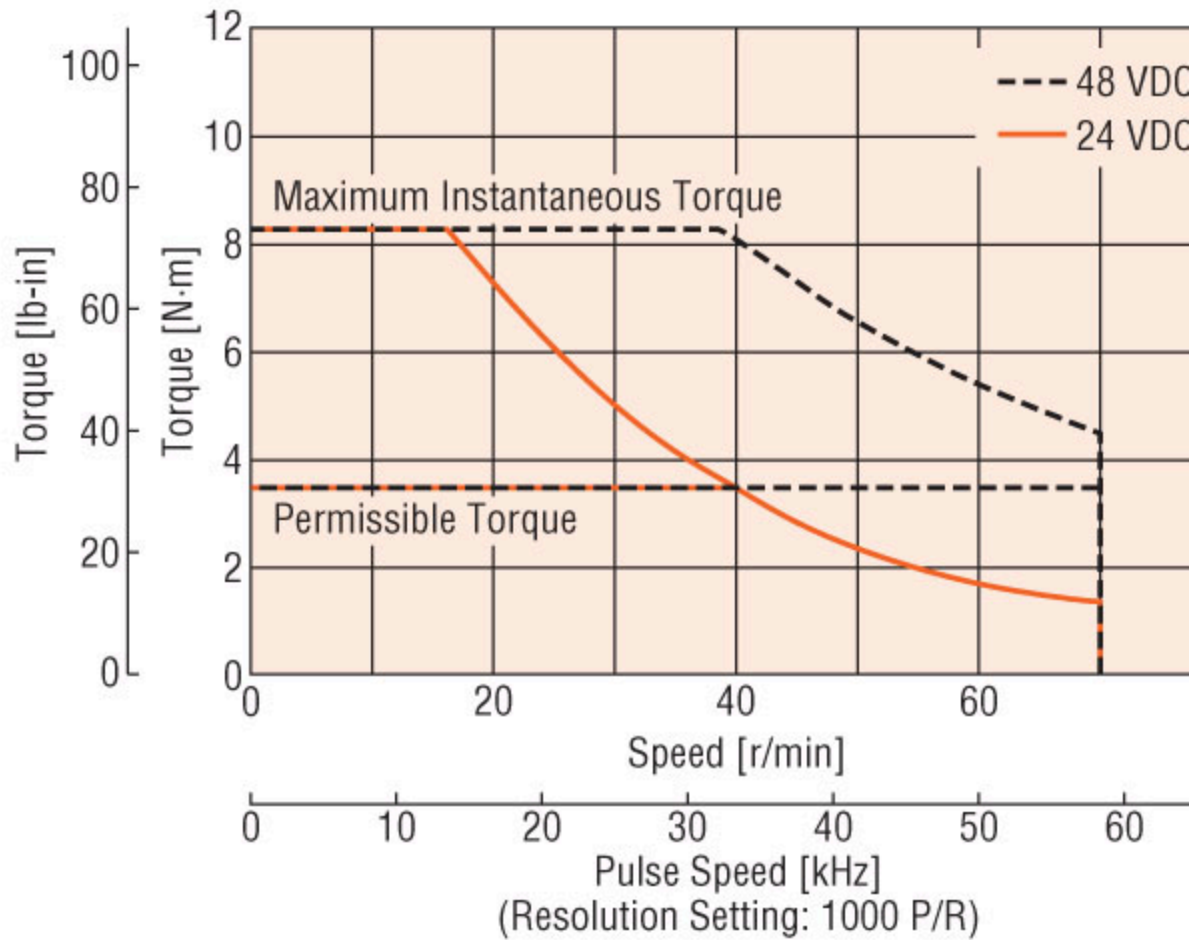

Rotation Direction

This indicates the rotation direction as viewed from the output shaft side of the motor (factory setting).

The rotation direction of the output gear shaft relative to the standard type motor output shaft varies depending on the gear type and gear ratio. Please check the following table.

Type	Gear Ratio	Rotation direction Relative to Motor Output Shaft
TS Geared	3.6, 7.2, 10	Same direction
	20, 30	Opposite direction
SH Geared Frame Size 28 mm (1.10 in.)	7.2, 36	Same direction
	9, 10, 18	Opposite direction
SH Geared Frame Size 42 mm (1.62 in.), 60 mm (2.36 in.)	3.6, 7.2, 9, 10	Same direction
	18, 36	Opposite direction
PS Geared	All gear ratios	Same direction
PLE Geared	All gear ratios	Opposite direction
FC Geared	All gear ratios	Same direction
Harmonic Geared	All gear ratios	Opposite direction

Standard Type Motor

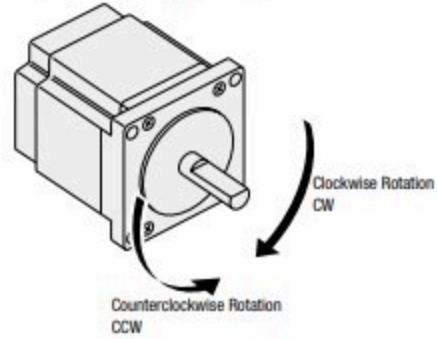

System Configuration

Pulse Input Type, Standard Type with Electromagnetic Brake

A single-axis system configuration with the **SCX11** Series controller is shown below.

* N

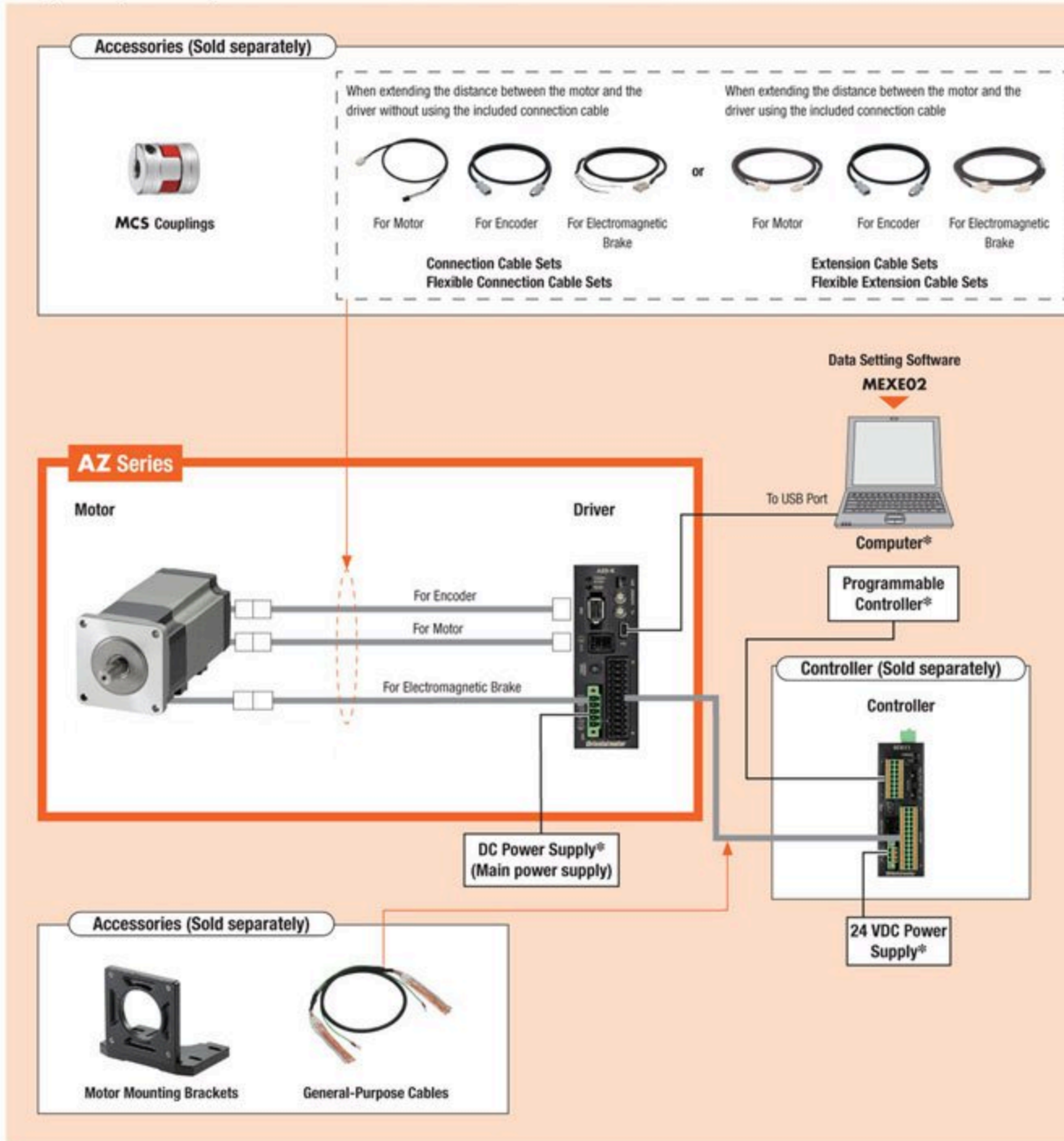

System Configuration

Built-in Controller Type, Standard Type with Electromagnetic Brake

An example of a configuration using I/O control or RS-485 communication is shown below.

* N

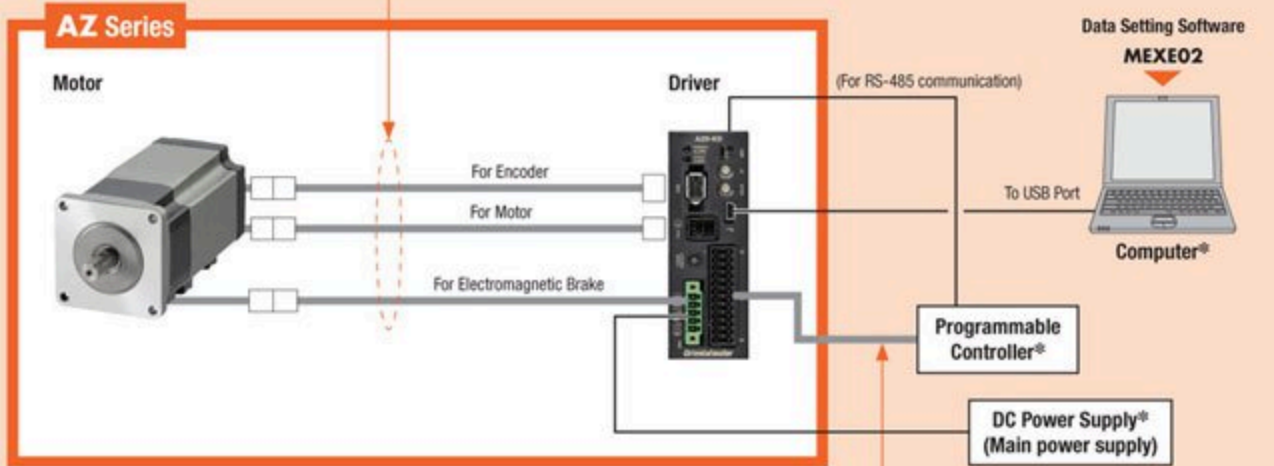
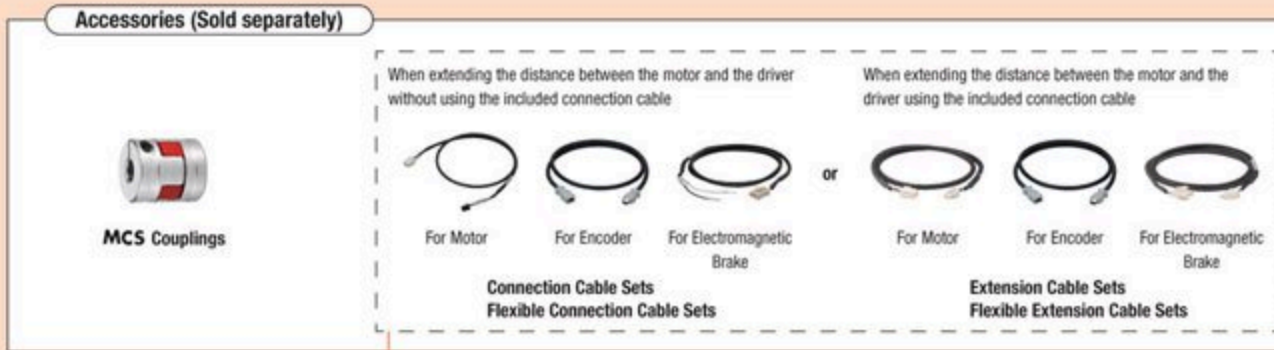

System Configuration

EtherCAT Drive Profile Support

The following is a system configuration example combining with the AZ Series DC power supply input sta electromagnetic brake.

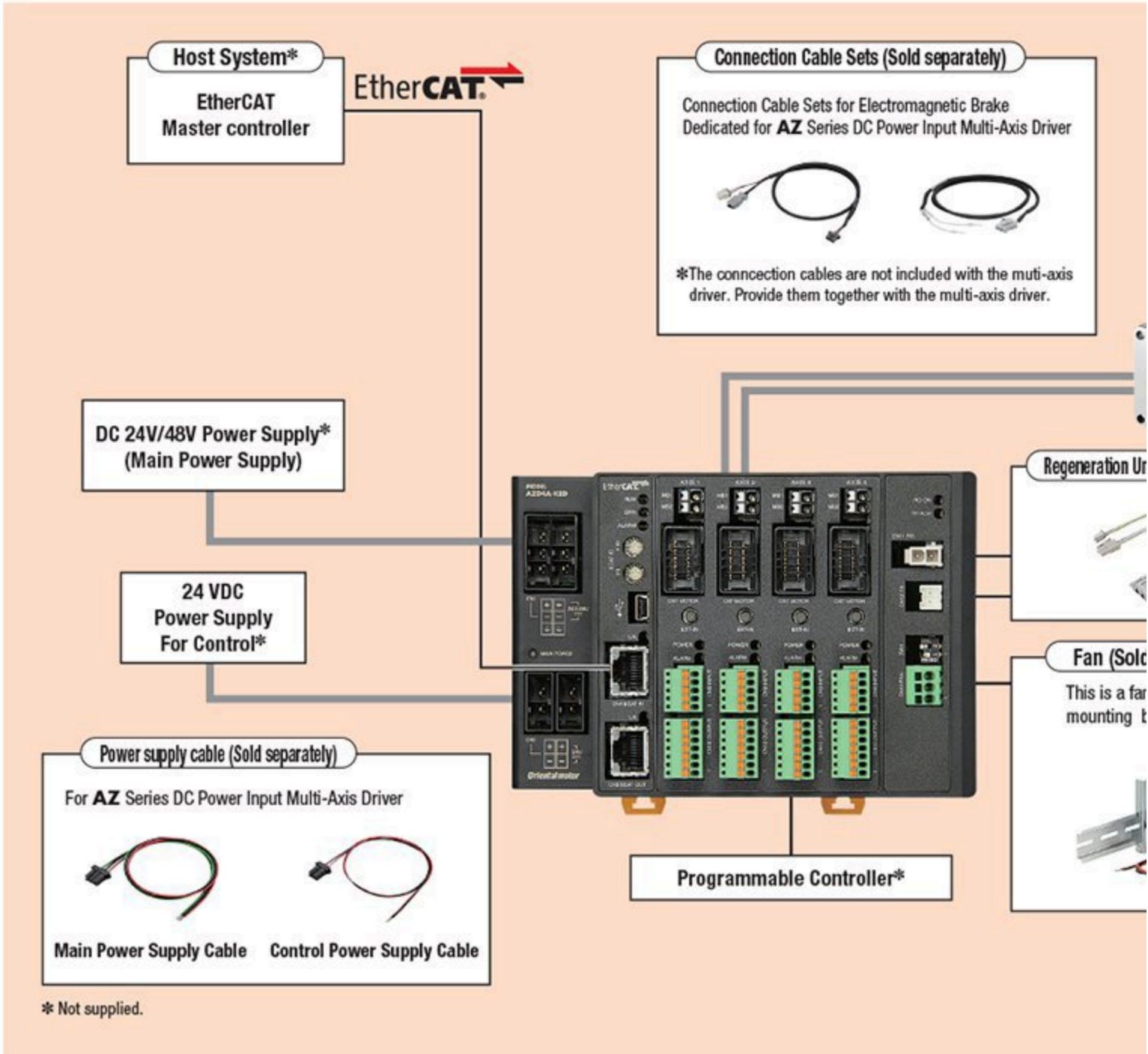

Product Number Code

● Motor

◇ Standard Type

AZM 6 6 A 0 K F

① ② ③ ④ ⑤ ⑥ ⑦

◇ PS, HPG, Harmonic Geared Type

AZM 6 6 A K - HP 15 F

① ② ③ ④ ⑥ ⑧ ⑨ ⑩

● TS Geared Type

AZM 6 6 A K - TS 7.2 U

① ② ③ ④ ⑤ ⑥ ⑦ ⑧

● FC Geared Type

AZM 6 6 A K - FC 7.2 U A

① ② ③ ④ ⑤ ⑥ ⑦ ⑧ ⑨

● Connection Cable Set / Flexible Connection Cable Set

CC 050 V Z □ F B 2

① ② ③ ④ ⑤ ⑥ ⑦ ⑧

①	Motor Type	AZM: AZ Series Motor
②	Motor Frame Size	1: 20 mm (0.79 in.) 2: 28 mm (1.10 in.) (Harmonic (1.18 in.)) 4: 42 mm (1.65 in.) (HPG Gear) 6: 60 mm (2.36 in.)
	Motor Case Length	
	Output Shaft Configuration	A: Single Shaft M: Electrom
⑤	Motor Specifications*	O: Straight I: Keyed
⑥	Gear Type	K: DC Power Supply Input Spe
⑦	Motor Cable Configuration	F: Horizontal Outlet Direction
⑧	Geared Type	PS: PS Geared Type HP: HPG Geared Type HS: Harmonic Geared Type
	Gear Ratio	
	Output Shaft Type	HPG Geared Type Blank: Shaft Output F: Flange

*For standard type, if there is no number indicating additional functionality, flat face specification.

①	Motor Type	AZM: AZ Series Motor
②	Motor Frame Size	4: 42 mm (1.65 in.) 6: 60 r
③	Motor Case Length	
④	Output Shaft Type	A: Single M: Type with Elec
⑤	Motor Type	K: DC Input Specification
⑥	Geared Type	TS: TS Geared Type
⑦	Gear Ratio	
⑧	Cable Outlet Direction	U: Upper Side L: Left Side

①	Motor Type	AZM: AZ Series Motor
②	Motor Frame Size	4: 42 mm (1.65 in.) 6: 60 r
③	Motor Case Length	
④	Output Shaft Type	A: Single M: Type with Elec
⑤	Motor Type	K: DC Input Specification
⑥	Geared Type	FC: FC Geared Type
⑦	Gear Ratio	
⑧	Cable Outlet Direction*	D: Down Side U: Upper Sid
⑨	Identification Symbol	A: Solid Shaft

*The cable The cable direction is when viewed from the gearhead side with t

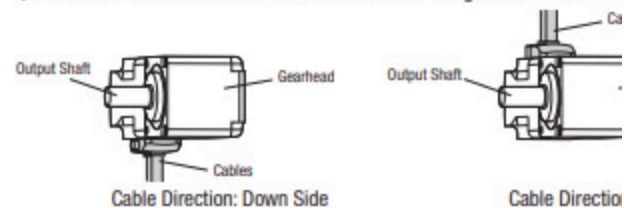

①		CC: Cable
②	Length	010: 1 m (3.3 ft.) 020: 2 m (6.6 f 050: 5 m (16.4 ft.) 070: 7 m (23 150: 15 m (49.2 ft.) 200: 20 m (E
	Reference Number	
	Applicable Product	Z: AZ Series
	Reference Number	Blank: Frame Size 42 mm (1.65 in.) [

⑤		40 mm (1.57 in.)), 60 mm (2.3 2: Frame Size 20 mm (0.79 in.), 28 r Geared Type is 30 mm (1.18 in.)]
⑥	Cable Type	F: Connection Cable Set R: Flexible Connection Cable Set
⑦	Description	Blank: Without Electromagnetic Brak B: Electromagnetic Brake Type
⑧	Cable Specifications	2: DC Power Supply Input

¹ Quoted Ship Date for orders placed before 12:00 pm PST. Quantities may affect Shipping Date.

©2017 - ORIENTAL MOTOR U.S.A. Corp. - All rights reserved.

Site Search...

